



RAYCHEM INSTALITE MOLDED BOOTS

ADVANCED MATERIALS SCIENCE DRIVES UP TO 30% WEIGHT SAVINGS . . . REDUCES INSTALLATION TIME WITH HIGH-PERFORMANCE HEAT-SHRINK SHAPE MEMORY BOOTS

iS *Rayfast*

INSTALITE MOLDED BOOTS

High-Performance Heat-Shrink Boots



WEIGHT SAVINGS

- 20% to 30% lighter than standard -25 parts

TIME SAVINGS

- Optimized interior geometry speeds installation time
- Faster recovery

RUGGED

- -75°C to 150°C temperature range
- Resists most common military fuels, oils, and greases
- Abrasion resistant

COMPATIBLE

- Part of System 25 harnessing components
- Lighter weight drop-in replacement for standard -25 boots
- Meets the requirements of VG 95343 Parts 6 and 18

APPLICATIONS

- Military ground systems
- Aerospace
- Marine

INSTALITE boots are a lighter weight alternative of our -25 heat-shrink boots. Utilizing our expertise in fluid-resistant, modified elastomers, we've created semi-rigid, abrasion-resistant boots that are up to 30% lighter than our standard -25 boots. INSTALITE boots offer the same balance of high-temperature fluid resistance and long-term heat resistance.

Product Performance

PHYSICAL CHARACTERISTICS

- **Tensile strength:** 10 MPa (1450 psi) min.
- **Ultimate elongation:** 400% min.
- **Specific gravity:** 1 (± 0.05)

THERMAL CHARACTERISTICS

- **Heat aging** (168 hr @ 160°C): 400% min. ultimate elongation
- **Heat shock** (4 hr @ 215°C): 400% min. ultimate elongation
- **Low-temperature flexing** (4 hr @ -75°C): No cracking
- **Flammability burn time:** 120 seconds max

ELECTRICAL

- **Electrical strength:** 15 MV/m (4.6 MV/ft)

FLUID RESISTANCE

(Aviation Fuel, Hydraulic Fluids, Lubricating Oil, Cleaning Fluids, Deicers)

- **After 24-hr immersion:** 8 MPa (1160 psi) min. tensile strength
300% min. ultimate elongation

DOCUMENTS

- **RW-3040:** Product specification
- **ELE-3COP-555:** Installation of 90° boot
- **ELE-3COP-554:** Installation of straight boot

TOOLING

- **Heat gun:** CV 1981

INSTALLATION TIME

(Timings are representative across the range based on our codes of practice)

- **System 25 boot:** 2 minutes 24 seconds
- **System 25L boot:** 1 minute 41 seconds

Visit www.te.com/INSTALITE to view our installation video.

TE Components ... TE Technology ... TE Know-how ...

AMP | Agastat | CII | Hartman | Kilovac | Microdot | Nanonics | Raychem | Rochester | DEUTSCH

Get your product to market faster with a smarter, better solution.

Instalite Molded Boots

Straight Boot

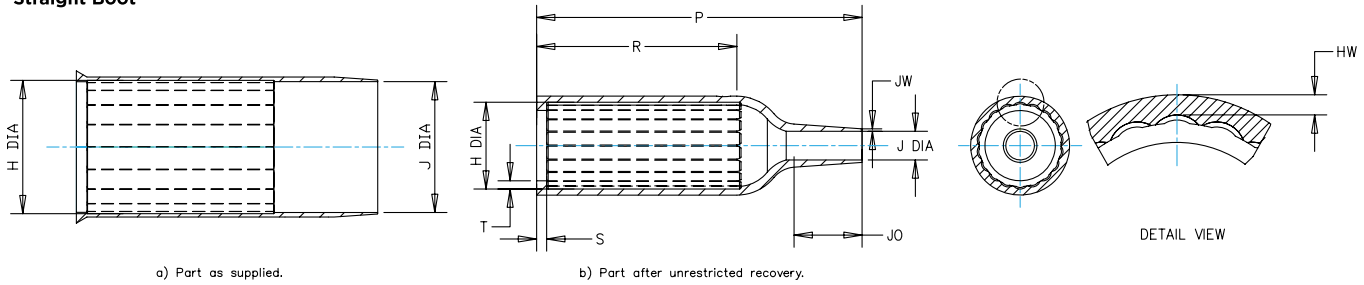

Part No.	H		J		P ±10% b	R ±10% b	HW ±20% b	JW Min. b	Avg Weight Savings
	Min. a	Max. b	Min. a	Max. b					
202K121-25L-0	24 [0.95]	10.4 [0.41]	24 [0.95]	5.6 [0.22]	38 [1.50]	21 [0.83]	1.3 [0.05]	0.9 [0.04]	20%
202K132-25L-0	30 [1.18]	14.2 [0.56]	30 [1.18]	5.9 [0.23]	55 [2.17]	32 [1.26]	1.3 [0.05]	1.0 [0.04]	20%
202K142-25L-0	31 [1.22]	18 [0.71]	31 [1.22]	7.1 [0.28]	67 [2.64]	35 [1.38]	1.2 [0.04]	1.0 [0.04]	20%
202K153-25L-0	36 [1.42]	22.4 [0.88]	36 [1.42]	8.4 [0.33]	80 [3.15]	42 [1.65]	1.5 [0.06]	1.0 [0.04]	23%
202K163-25L-0	43 [1.69]	28.2 [1.11]	43 [1.69]	9.9 [0.39]	99 [3.90]	61 [2.40]	2.0 [0.08]	1.2 [0.05]	28%
202K174-25L-0	60 [2.36]	35.1 [1.38]	60 [2.36]	15.7 [0.62]	130 [5.12]	72 [2.83]	2.3 [0.09]	1.5 [0.06]	22%
202K185-25L-0	66 [2.60]	44.5 [1.75]	66 [2.60]	16.8 [0.66]	170 [6.69]	90 [3.54]	1.8 [0.07]	2.0 [0.08]	21%

See the latest Specification Control Document for full dimensions

Right-Angle Boot

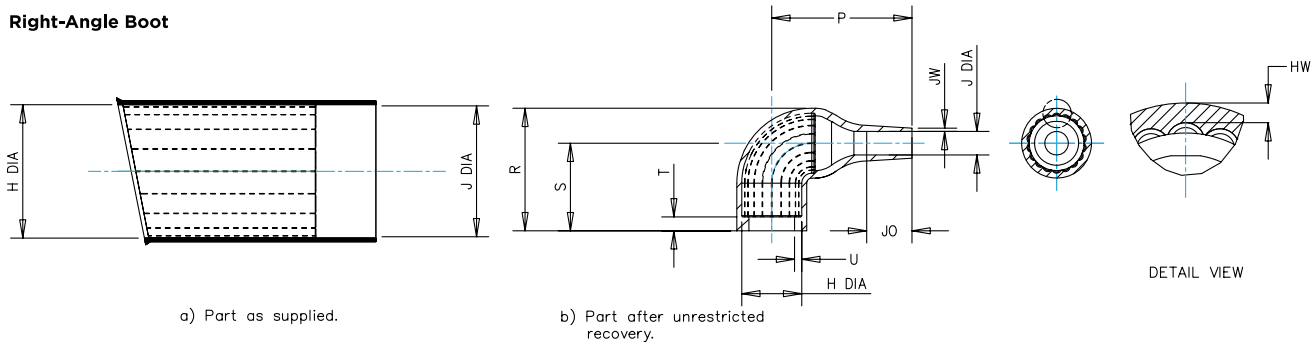

Part No.	H		J		P ±10% b	R ±10% b	S ±10% b	HW ±20% b	JW Min. b	Avg Weight Savings
	Min. a	Max. b	Min. a	Max. b						
222K121-25L-0	24 [0.95]	10.4 [0.41]	24 [0.95]	5.6 [0.22]	25 [0.98]	25 [0.98]	19 [0.75]	1.3 [0.05]	0.5 [0.02]	30%
222K132-25L-0	30 [1.18]	14.2 [0.56]	30 [1.18]	5.9 [0.23]	32 [1.26]	27 [1.06]	20 [0.79]	1.3 [0.05]	0.8 [0.03]	26%
222K142-25L-0	31 [1.22]	18 [0.71]	31 [1.22]	7.1 [0.28]	39 [1.54]	31 [1.22]	21 [0.83]	1.2 [0.04]	1.0 [0.04]	21%
222K152-25L-0	36 [1.42]	22.4 [0.88]	36 [1.42]	8.4 [0.33]	46 [1.81]	38 [1.50]	26 [1.02]	1.5 [0.06]	1.0 [0.04]	26%
222K163-25L-0	43 [1.69]	28.2 [1.11]	43 [1.69]	9.9 [0.39]	55 [2.17]	45 [1.77]	30 [1.18]	2.0 [0.08]	1.0 [0.04]	21%
222K174-25L-0	60 [2.36]	35.1 [1.38]	60 [2.36]	15.7 [0.62]	80 [3.15]	54 [2.13]	35 [1.38]	2.3 [0.09]	1.5 [0.06]	23%
222K185-25L-0	66 [2.60]	44.5 [1.75]	66 [2.60]	16.8 [0.66]	108 [4.25]	68 [2.68]	42 [1.65]	1.8 [0.07]	2.0 [0.08]	25%

See the latest Specification Control Document for full dimensions

Tel: +44(0) 1793616700 • Fax: +44(0) 1793 644304
uksales@is-rayfast.com • export@is-rayfast.com

www.is-rayfast.com

2 Lydiard Fields, Swindon, Wiltshire, SN5 8UB

